

Type B

The flat-top version of Lindapter's standard clamp, for moderate tensile loading. Can also be used with Type A in a Girder Clamp configuration.

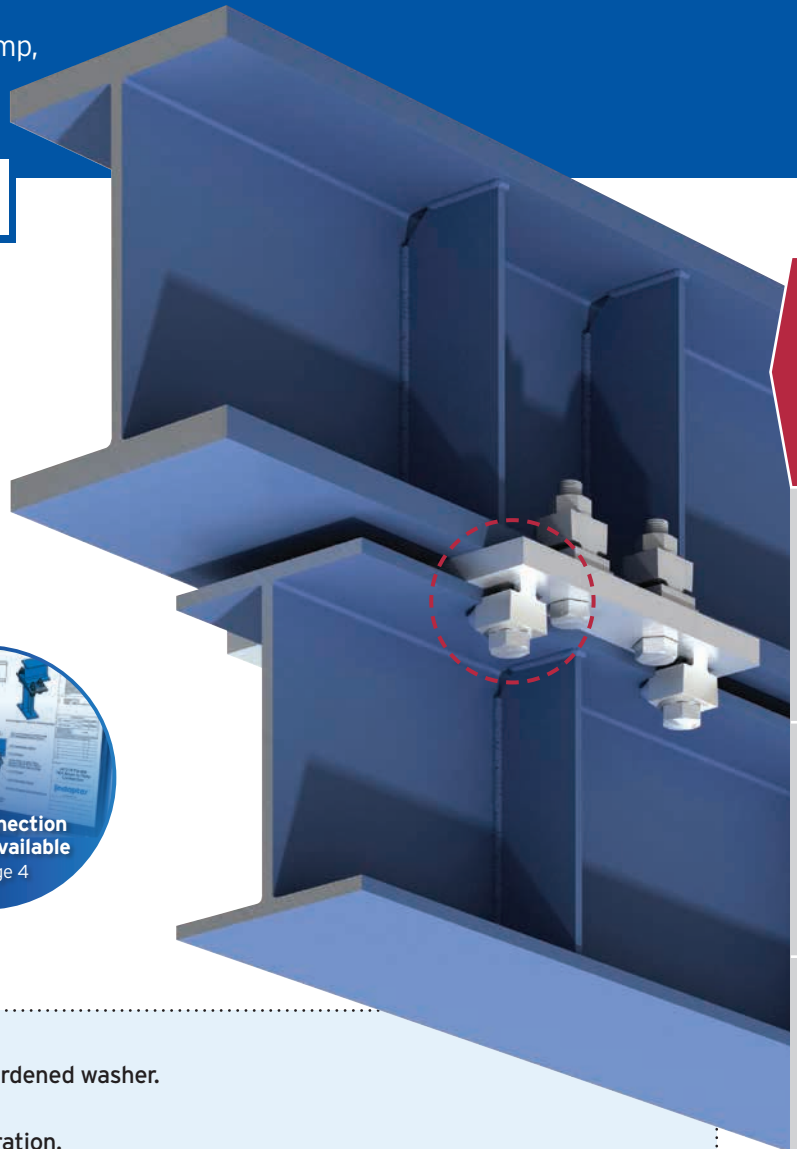
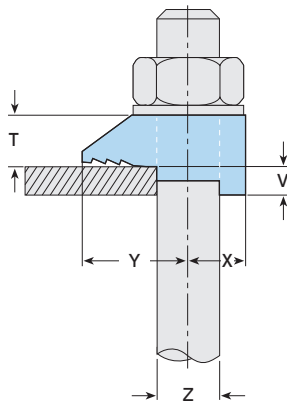
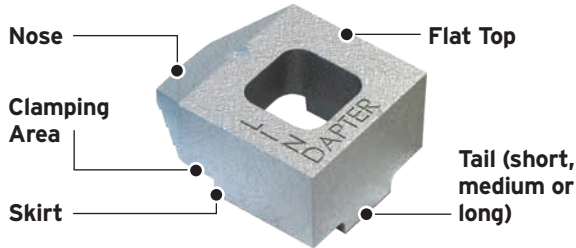

GIRDER CLAMPS

RAIL FIXINGS

LIFTING POINTS

HULL-BOLT

FLOOR FIXINGS

SUPPORT FIXINGS

DECKING FIXINGS

- UKCA, CE Mark, Lloyd's Register and TÜV approved.
- Flat top allows the bolt head or nut to rotate on a hardened washer.
- Suitable for use with bolts, studs, tie rods, J-bolts.
- Supports up to 78.8kN in a tensile four-bolt configuration.
- Independently approved for dynamic loading.
- For higher loads the Type AF should be used, see page 15.

- Packings are available to increase the clamping range, see page 12.
- Location plate / end plate details can be found on page 13.
- Dynamic load testing has been performed in accordance with EN 1993-1-9. Contact our Technical Support team for load data.



For Characteristic Resistances when designing a connection to Eurocode 3, refer to DoP No.003 (CE) or DoP No.103 (UKCA) on Lindapter's website or request a DoP Brochure.



Material: Malleable iron, zinc plated or hot dip galvanised.

Product Code	Bolt 8.8 Z	Safe Working Loads (FOS 5:1)			Tightening Torque*	Y mm	X mm	Dimensions			T mm	Width mm
		Tensile / 1 Bolt kN	Slip / 2 Bolts kN	Tail Length V								
				short mm				medium mm	long mm			
B08	M8	1.0	-	6	16	8	-	4	-	8	20	
B10	M10	1.5	-	20	20	11	4	5	7	10	26	
B12	M12	5.8	0.9	69	26	13	4.5	6	9.5	12	29	
B16	M16	8.5	1.7	147	30	16	5.5	8	11	16	36	
B20	M20	14.7	3.0	285	36	19	7	10	12.5	19	46	
B24	M24	19.7	4.5	491	48	25	9	12	16	25	55	

* Torque figures based on bolts / setscrews in an unlubricated condition. For further information on lubricated fasteners see page 72.

Packing Pieces for Types A and B

These packing pieces are compatible with the Type A and Type B clamps and are used to increase the clamping range to suit flange thicknesses. Types A and B are available with three different tail lengths (short, medium or long) and the correct combination of packing pieces should be used.

Packing Pieces

Type CW

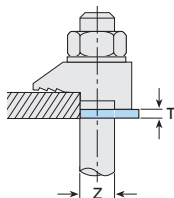

Mild steel, zinc plated or hot dip galvanised.

Product Code	Bolt Size Z	Dimension T (mm)
CW08*	M8	2
CW10	M10	2
CW12	M12	2.5
CW16	M16	3
CW20	M20	4
CW24	M24	4

* CW08 is only available zinc plated.

Type P1/ P2 short

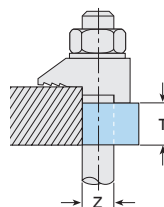
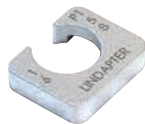

Mild steel, malleable iron, zinc plated or hot dip galv.

Product Code	Bolt Size Z	Dimension T (mm)
P1S08	M8	4
P1S10	M10	5
P1S12	M12	6
P1S16	M16	8
P1S20	M20	10
P1S24	M24	12

P2S10	M10	10
P2S12	M12	12
P2S16	M16	16
P2S20	M20	20
P2S24	M24	25

Also Available

Type W

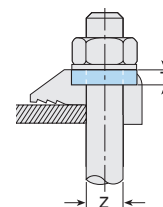

Mild steel, malleable iron, zinc plated or hot dip galv.

Product Code	Bolt Size Z	Dimension T (mm)
W08	M8	4
W10	M10	5.5
W12	M12	6
W16	M16	8
W20	M20	10

Note: The Type W is used to fill the recess in the Type A to convert it into a flat top clamp to enable the bolt head or nut to be rotated on a hardened washer.

Tail Length / Packing Piece Combinations for Types A and B

Choose the correct Type A/B configuration for your application using the table below. For example, a M24 Type A/B on a 26mm flange requires 1 x Type A/B short tail (S), 1 x Type CW (CW) and 1 x Type P1 short (P1S).

- For thicker flanges contact Lindapter.
- Other combinations than what is shown below may be possible. Contact our Technical Support team to discuss your requirements.

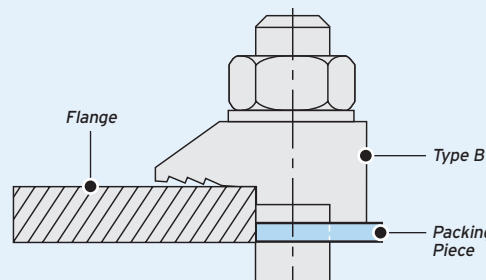

Flange Thickness mm	M12				M16				M20				M24				
	A/B	CW	P1S	P2S	A/B	CW	P1S	P2S	A/B	CW	P1S	P2S	A/B	CW	P1S	P2S	
5	S	-	-	-	S	-	-	-	-	-	-	-	-	-	-	-	-
6	M	-	-	-	S	-	-	-	-	-	-	-	-	-	-	-	-
7	S	1	-	-	M	-	-	-	S	-	-	-	-	-	-	-	-
8	S	1	-	-	M	-	-	-	S	-	-	-	-	-	-	-	-
9	M	1	-	-	S	1	-	-	M	-	-	-	S	-	-	-	-
10	L	-	-	-	L	-	-	-	M	-	-	-	S	-	-	-	-
11	M	2	-	-	L	-	-	-	S	1	-	-	M	-	-	-	-
12	L	1	-	-	S	2	-	-	S	1	-	-	M	-	-	-	-
13	S	1	1	-	S	-	1	-	L	-	-	-	S	1	-	-	-
14	S	1	1	-	L	1	-	-	M	1	-	-	S	1	-	-	-
15	L	2	-	-	S	3	-	-	S	2	-	-	L	-	-	-	-
16	L	-	1	-	M	-	1	-	S	2	-	-	L	-	-	-	-
17	M	2	1	-	L	2	-	-	S	-	1	-	S	2	-	-	-
18	M	-	-	1	L	2	-	-	M	2	-	-	S	2	-	-	-
19	S	1	-	1	L	-	1	-	S	3	-	-	L	1	-	-	-
20	S	1	-	1	L	3	-	-	M	-	1	-	L	1	-	-	-
21	M	1	-	1	L	3	-	-	S	1	1	-	S	-	1	-	-
22	L	-	-	1	L	1	1	-	M	3	-	-	S	-	1	-	-
23	S	-	1	1	L	1	1	-	L	-	1	-	M	-	1	-	-
24	M	-	1	1	M	-	-	1	M	1	1	-	M	-	1	-	-
25	S	1	1	1	L	2	1	-	S	2	1	-	S	1	1	-	-
26	S	1	1	1	L	2	1	-	S	2	1	-	S	1	1	-	-
28	L	-	1	1	S	2	-	1	M	2	1	-	L	-	1	-	-
30	M	-	-	2	L	1	-	1	M	-	-	1	S	2	1	-	-

A/B = Type A/B S = A/B short M = A/B medium L = A/B long CW = Type CW P1S = Type P1 short P2S = Type P2 short

Location and End Plates for Types A and B

These plates ensure the clamps and bolts are located in the correct position relative to the supporting steelwork. If you would like help choosing a suitable plate, please contact Lindapter.

Location Plate

Location plates are required when securing two sections together with clamps attached to the upper and lower sections with both clamps directly opposing each other.

The plate is positioned between the two sections to hold the bolts at the correct centres and should be fabricated to the dimensions shown in the table below.

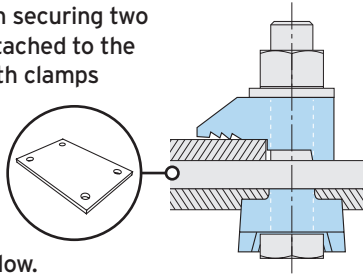

Material: Structural steel grade S275 JR or JO. For other grades contact Lindapter.

Bolt Size	Hole Ø d mm	Plate Thick. mm	Hole Centres C1 mm	Length min L1 mm	Hole Centres C2 mm	Width min L2 mm
M8	9	6	B ₁ + 9	B ₁ + 36	B ₂ + 9	B ₂ + 36
M10	11	8	B ₁ + 11	B ₁ + 44	B ₂ + 11	B ₂ + 44
M12	14	8	B ₁ + 14	B ₁ + 54	B ₂ + 14	B ₂ + 54
M16	18	10	B ₁ + 18	B ₁ + 70	B ₂ + 18	B ₂ + 70
M20	22	12	B ₁ + 22	B ₁ + 88	B ₂ + 22	B ₂ + 88
M24	26	15	B ₁ + 26	B ₁ + 104	B ₂ + 26	B ₂ + 104

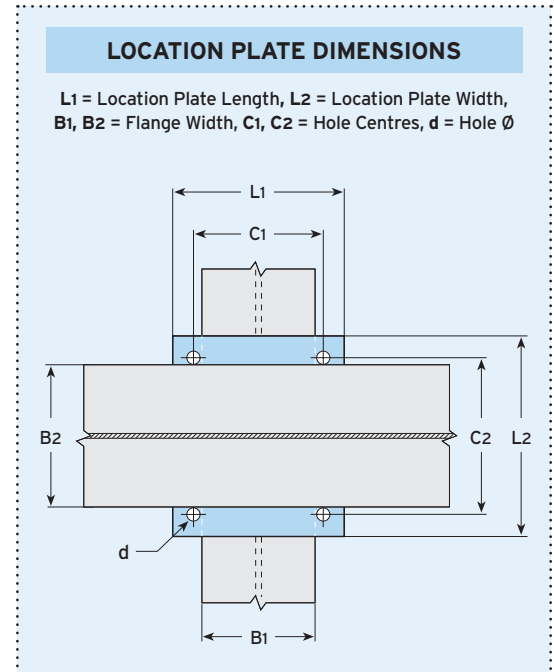

End Plate

End Plates should be used when clamps are attached to the supporting section only.

The End Plate holds the bolts at the correct centres and should be fabricated to the dimensions shown in the table below.

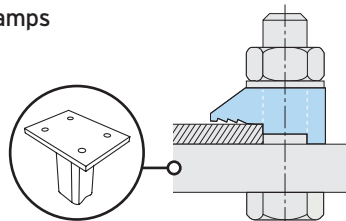

Material: Structural steel grade S275 JR or JO. For other grades contact Lindapter.

Bolt Size	Hole Ø d mm	Plate Thick. ¹⁾ mm	Hole Centre C1 mm	Length min L1 mm	Hole Centre min C2 mm	Width min L2 mm
M8	9	10	B + 9	B + 36	40	C ₂ + 40
M10	11	12	B + 11	B + 44	50	C ₂ + 40
M12	14	12	B + 14	B + 54	60	C ₂ + 50
M16	18	15	B + 18	B + 70	70	C ₂ + 60
M20	22	20	B + 22	B + 88	90	C ₂ + 70
M24	26	25	B + 26	B + 104	110	C ₂ + 90

¹⁾ Depending on the type of connection and associated end plate use, the thickness may need to be modified to comply with accepted local design codes.

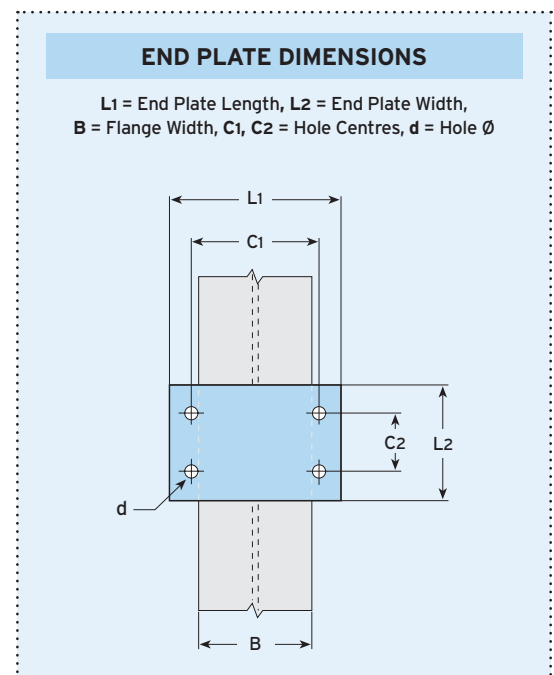

- To calculate the bolt length, add up the total distance that the bolt will pass through, plus half of the bolt diameter. Then round up the total to the nearest available bolt length. An example can be found on page 8.
- If drilling through the flange of the supported steelwork please contact Lindapter to ensure suitability.