

Type AF

A heavy duty clamp offering the highest load capacities of all Lindapter's High Slip Resistance clamps. Hot dip galvanised corrosion protection.

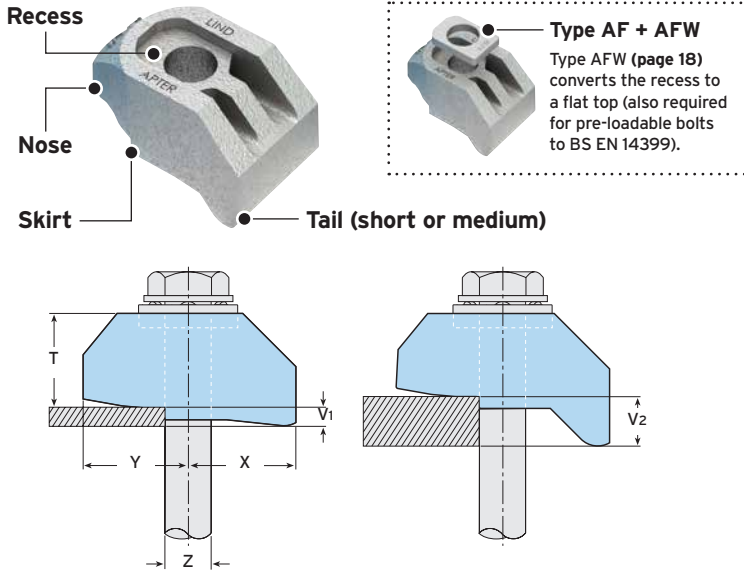

**HIGH SLIP
RESISTANCE**

- High slip resistance for tensile, frictional and combined load applications.
- 70kN static slip resistance or 250kN tensile (AF24 with 4 property class 10.9 fasteners).
- Independently approved for dynamic loading.
- Recess holds the bolt head captive (property class 8.8).
- For parallel and tapered flanges up to 10°.
- The tail spans slotted clearance holes.

➤ Packings are available to increase the clamping range, see page 18. Location plate / end plate details can be found on page 19.

➤ Lindapter recommends the use of DTI Washers conforming to EN14399-9 with the Type AF, see page 72.

➤ Dynamic load testing has been performed in accordance with EN 1993-1-9. Contact our Technical Support team for load data.



For Characteristic Resistances when designing a connection to Eurocode 3, refer to DoP No.004 (CE) or DoP No.104 (UKCA) on Lindapter's website or request a DoP Brochure.



Material: SG iron, hot dip galvanised.

Product Code	Bolt		Safe Working Loads				Tightening Torque*	Dimensions					
	Size Z	Property Class ⁴⁾	Tensile / 1 Bolt (FOS 5:1) kN	Slip ¹⁾ / 2 Bolts (FOS 2:1)		Tail Length		Y	X	T	T	Width	
				Painted Steelwork ²⁾ kN	Galvanised Steelwork kN	short V1 mm							medium V2 mm
AF12	M12	8.8	8.5	3.4	3.9	90	5	12.5	27	27	17	22	39
AF16	M16	8.8	16.0	8.0	10.0	240	8	15	35	37	22	27	49
AF20	M20	8.8	26.3	13.0	16.0	470	10	18	40	39	25	31	56
AF24	M24	8.8	40.0	24.0	30.0	800	15	30	48	60	32	42	82
AF12	M12	10.9	10.0	4.0	5.2	130	5	12.5	27	27	17	22	39
AF16	M16	10.9	19.5	11.0	12.0	300	8	15	35	37	22	27	49
AF20	M20	10.9	30.0	20.0	25.0	647	10	18	40	39	25	31	56
AF24	M24	10.9	62.5 ³⁾	28.0	35.0	1000	15	30	48	60	32	42	82

1) Slip resistant values calculated against movement exceeding 0.1mm.

2) Shot blast and painted steelwork.

3) 3.2:1 Factor of Safety.

4) For ease of installation when using 10.9 bolts Lindapter recommends using fastener assemblies to EN 14399-1.

* Torque figures based on bolts / setscrews in an unlubricated condition. For further information on lubricated fasteners see page 72.

Packing Pieces for Types AF and AAF

Packing pieces are used to increase the clamping range to suit a range of flange thicknesses. The Type AF is available with two different tail lengths (short and medium) and the correct combination of packing pieces should be used, see the table at the bottom of the page.

Packing Pieces

Type AFCW

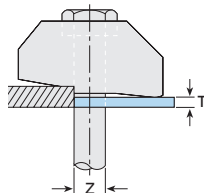

Mild steel, hot dip galvanised.

Product Code	Bolt Size Z	Dimension T (mm)
AF12CW	M12	2
AF16CW	M16	2
AF20CW*	M20	2

* Not compatible with Type AAF clamp.

Note: The AFCW has a slight bend along its centre line which flattens out during installation.

Type AFP1 / AFP2 / AAFP3

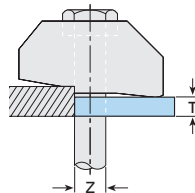

Mild steel, hot dip galvanised.

Product Code	Bolt Size Z	Dimension T (mm)
AF12P1	M12	5
AF16P1	M16	5
AF20P1*	M20	5
AF24P1*	M24	5

AF12P2	M12	10
AF16P2	M16	10
AF20P2*	M20	10
AF24P2*	M24	10

AAAF20P3	M20	20
----------	-----	----

* Not compatible with Type AAF clamp.

Also Available

Type AFW

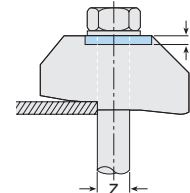

SG iron, mild steel, hot dip galvanised.

Product Code	Bolt Size Z	Dimension T (mm)
AFW12	M12	5
AFW16	M16	5
AFW20	M20	6
AFW24	M24	10

Note: Type AFW converts the recess to a flat top to enable the bolt head or nut to be rotated on a hardened washer and is required when using preloadable bolts to BS EN 14399.

Tail Length / Packing Piece Combinations for Type AF

Choose the correct combination for your configuration using the table below. Please note these calculations are for parallel flanges and beams up to 10° slopes only. For example, a M20 Type AF on a 40mm flange requires 1 x Type AF medium tail (M), 1 x Type AFCW and 2 x Type AFP2.

- For thicker flanges contact Lindapter.
- Other combinations than what is shown below may be possible. Contact our Technical Support team to discuss your requirements.

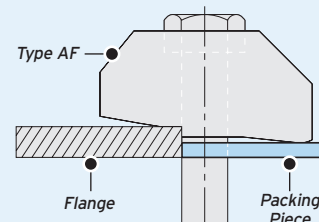

Flange Thickness mm	M12				M16				M20				M24			Flange Thickness mm	M12				M16				M20				M24		
	AF	AFCW	AFP1	AFP2	AF	AFCW	AFP1	AFP2	AF	AFCW	AFP1	AFP2	AF	AFP1	AFP2		AF	AFCW	AFP1	AFP2	AF	AFCW	AFP1	AFP2	AF	AFCW	AFP1	AFP2	AF	AFP1	AFP2
5	S	-	-	-	-	-	-	-	-	-	-	-	-	-	-	28	M	-	1	1	S	-	-	2	M	-	-	1	M	-	-
6	S	-	-	-	-	-	-	-	-	-	-	-	-	-	-	29	M	1	1	1	M	-	1	1	M	-	-	1	M	-	-
7	S	1	-	-	S	-	-	-	-	-	-	-	-	-	30	S	-	1	2	M	-	1	1	M	1	-	1	M	-	-	
8	S	1	-	-	S	-	-	-	-	-	-	-	-	-	31	S	-	1	2	M	-	1	1	M	1	-	1	M	-	-	
9	S	2	-	-	S	-	-	-	S	-	-	-	-	-	32	M	-	-	2	M	1	1	1	M	-	1	1	M	1	-	
10	S	-	1	-	S	1	-	-	S	-	-	-	-	-	33	M	-	-	2	M	1	1	1	M	-	1	1	M	1	-	
11	S	3	-	-	S	1	-	-	S	-	-	-	-	-	34	M	1	-	2	M	-	-	2	M	-	1	1	M	1	-	
12	S	1	1	-	S	2	-	-	S	1	-	-	S	-	35	S	-	-	3	M	-	-	2	S	-	1	2	M	1	-	
13	M	-	-	-	S	-	1	-	S	1	-	-	S	-	36	S	-	-	3	M	-	-	2	M	1	1	1	M	1	-	
14	M	1	-	-	S	3	-	-	S	2	-	-	S	-	37	M	-	1	2	M	1	-	2	M	-	-	2	M	1	-	
15	S	-	-	1	M	-	-	-	S	-	1	-	S	-	38	M	-	1	2	S	-	-	3	M	-	-	2	M	-	1	
16	M	2	-	-	M	-	-	-	S	3	-	-	S	-	39	M	1	1	2	M	-	1	2	M	-	-	2	M	-	1	
17	M	-	1	-	M	1	-	-	M	-	-	-	S	-	40	S	-	1	3	M	-	1	2	M	1	-	2	M	-	1	
18	M	-	1	-	S	-	-	1	M	-	-	-	S	1	41	S	-	1	3	M	-	1	2	M	1	-	2	M	-	1	
19	M	1	1	-	M	-	1	-	M	-	-	-	S	1	42	M	-	-	3	M	1	1	2	M	-	1	2	M	-	1	
20	S	-	1	1	M	-	1	-	M	1	-	-	S	1	43	S	-	-	3	S	-	1	3	M	-	1	2	M	1	1	
21	M	2	1	-	M	-	1	-	M	1	-	-	S	1	44	M	1	-	3	M	-	-	3	M	-	1	2	M	1	1	
22	M	2	1	-	M	1	1	-	M	2	-	-	S	1	45	S	-	-	4	M	-	-	3	M	1	1	2	M	1	1	
23	M	-	-	1	M	1	1	-	M	-	1	-	S	-	46	S	-	-	4	M	-	-	3	M	1	1	2	M	1	1	
24	M	1	-	1	M	-	-	1	M	1	1	-	S	-	47	M	-	1	3	M	1	-	3	M	-	-	3	M	1	1	
25	S	-	-	2	M	-	-	1	M	1	1	-	S	-	48	M	-	1	3	S	-	-	4	M	-	-	3	M	-	2	
26	M	2	-	1	M	-	-	1	S	1	1	1	S	-	49	S	-	1	4	M	-	1	3	M	-	-	3	M	-	2	
27	M	2	-	1	M	1	-	1	S	1	1	1	M	-	50	S	-	1	4	M	-	1	3	M	1	-	3	M	-	2	

AF = Type AF | AFCW = Type AFCW | AFP1 = Type AFP1 | AFP2 = Type AFP2 | S = AF short | M = AF medium

Location and End Plates for Types AF, AAF and CF

These plates ensure the clamps and bolts are located in the correct position relative to the supporting steelwork. If you would like help choosing a suitable plate, please contact Lindapter.

Location Plate

Location plates are required when securing two sections together with clamps attached to the upper and lower sections with both clamps directly opposing each other.

The plate is positioned between the two sections to hold the bolts at the correct centres and should be fabricated to the dimensions shown in the table below.

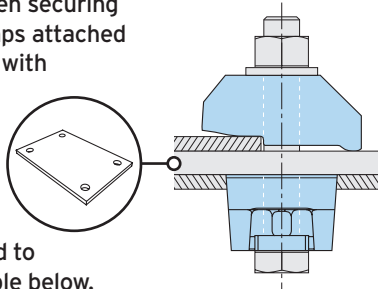

Material: Structural steel grade S355 JR, JO or J2. For other grades contact Lindapter.

Bolt Size	Hole Ø d mm	Plate Thickness		Hole Centres C1 mm	Length min L1 mm	Hole Centres C2 mm	Width min L2 mm
		8.8 mm	10.9 mm				
M12	14	10	12	B ₁ + 14	B ₁ + 90	B ₂ + 14	B ₂ + 90
M16	18	15	15	B ₁ + 18	B ₁ + 110	B ₂ + 18	B ₂ + 110
M20	22	20	20	B ₁ + 22	B ₁ + 150*	B ₂ + 22	B ₂ + 150*
M24	26	25	25	B ₁ + 26	B ₁ + 180	B ₂ + 26	B ₂ + 180

* Plate length / width for Type AF size M20 can be reduced to 130mm if required.

LOCATION PLATE DIMENSIONS

L₁ = Location Plate Length, L₂ = Location Plate Width, B₁, B₂ = Flange Width, C₁, C₂ = Hole Centres, d = Hole Ø

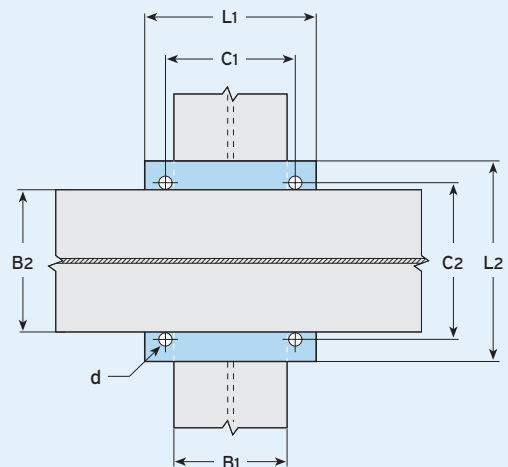

End Plate

End Plates should be used when clamps are attached to the supporting section only.

The End Plate holds the bolts at the correct centres and should be fabricated to the dimensions shown in the table below.

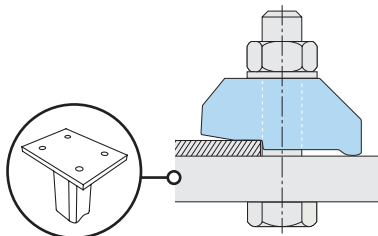

Material: Structural steel grade S355 JR, JO or J2. For other grades contact Lindapter.

Bolt Size	Hole Ø d mm	Plate Thickness ¹⁾		Hole Centres C1 mm	Length min L1 mm	Hole Centres min C2 mm	Width min L2 mm
		8.8 mm	10.9 mm				
M12	14	15	20	B + 14	B + 90	80	C ₂ + 80
M16	18	20	25	B + 18	B + 110	100	C ₂ + 100
M20	22	25	25	B + 22	B + 150*	180	C ₂ + 180
M24	26	30	30	B + 26	B + 180	200	C ₂ + 200

* Plate length for Type AF size M20 can be reduced to 130 if required.

¹⁾ Depending on the type of connection and associated end plate use, the thickness may need to be modified to comply with accepted local design codes.

END PLATE DIMENSIONS

L₁ = End Plate Length, L₂ = End Plate Width, B = Flange Width, C₁, C₂ = Hole Centres, d = Hole Ø

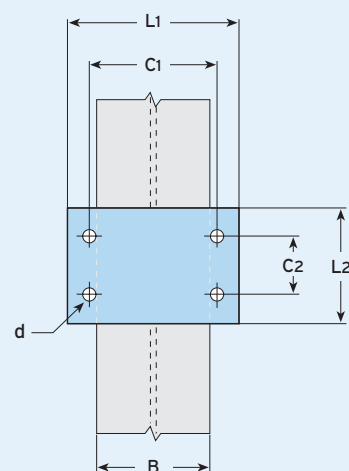

- To calculate the bolt length, add up the total distance that the bolt will pass through, plus half of the bolt diameter. Then round up the total to the nearest available bolt length. An example can be found on page 8.
- If drilling through the flange of the supported steelwork please contact Lindapter to ensure suitability.