

Public-law institution jointly founded by the federal states and the Federation

European Technical Assessment Body
for construction products



European Technical Assessment

ETA-21/0055
of 11 November 2024

English translation prepared by DIBt - Original version in German language

General Part

Technical Assessment Body issuing the European Technical Assessment:

Deutsches Institut für Bautechnik

Trade name of the construction product

E-JET X Screws

Product family to which the construction product belongs

E-JET X Screws for use in timber constructions

Manufacturer

Verbindungselemente Engel GmbH
Weltestraße 2+4
88250 Weingarten
DEUTSCHLAND

Manufacturing plant

70459-01

This European Technical Assessment contains

29 pages including 5 annexes which form an integral part of this assessment

This European Technical Assessment is issued in accordance with Regulation (EU) No 305/2011, on the basis of

EAD 130118-01-0603

This version replaces

ETA-21/0055 issued on 21 May 2021

The European Technical Assessment is issued by the Technical Assessment Body in its official language. Translations of this European Technical Assessment in other languages shall fully correspond to the original issued document and shall be identified as such.

Communication of this European Technical Assessment, including transmission by electronic means, shall be in full. However, partial reproduction may only be made with the written consent of the issuing Technical Assessment Body. Any partial reproduction shall be identified as such.

This European Technical Assessment may be withdrawn by the issuing Technical Assessment Body, in particular pursuant to information by the Commission in accordance with Article 25(3) of Regulation (EU) No 305/2011.

Specific Part

1 Technical description of the product

E-JET X screws are self-tapping screws made of special carbon steel. The screws are hardened. The screws have a corrosion protection according to Annex A.2.6 and an antifriction coating. The outer thread diameter is not less than 6.0 mm and not greater than 14.0 mm. The overall length of the screws is ranging from 16 mm to 1500 mm. Further dimensions are shown in Annex 5.

The washers are made from carbon steel. The dimensions of the washers are given in Annex 5.

All E-JET X screws achieve a bending angle α of at least $45/d^{0.7} + 20$, where d is the outer thread diameter of the screws.

2 Specification of the intended use in accordance with the applicable European Assessment Document

The performances given in Section 3 are only valid if the screws are used in compliance with the specifications and conditions given in Annex 1 and 2.

The verifications and assessment methods on which this European Technical Assessment is based lead to the assumption of a working life of the screws of at least 50 years. The indications given on the working life cannot be interpreted as a guarantee given by the producer, but are to be regarded only as a means for choosing the right products in relation to the expected economically reasonable working life of the works.

3 Performance of the product and references to the methods used for its assessment

3.1 Mechanical resistance and stability (BWR 1)

Essential characteristic	Performance
Dimensions	See Annex 5
Characteristic yield moment	See Annex 2
Bending angle	See Annex 2
Characteristic withdrawal parameter	See Annex 2
Characteristic head pull-through parameter	See Annex 2
Characteristic tensile strength	See Annex 2
Characteristic yield strength	See Annex 2
Characteristic torsional strength	See Annex 2
Insertion moment	See Annex 2
Spacings, end and edge distances of the screws and minimum thickness of the wood-based material	See Annex 2
Slip modulus for mainly axially loaded screws	See Annex 2
Durability against corrosion	See Annex 2

3.2 Safety in case of fire (BWR 2)

Essential characteristic	Performance
Reaction to fire	Class A1

3.3 Safety and accessibility in use (BWR 4)

Same as BWR 1.

4 Assessment and verification of constancy of performance (AVCP) system applied, with reference to its legal base

In accordance with EAD No. 130118-01-0603 the applicable European legal act is: 97/176/EC.
The system to be applied is: 3

5 Technical details necessary for the implementation of the AVCP system, as provided for in the applicable EAD

Technical details necessary for the implementation of the AVCP system are laid down in the control plan deposited with Deutsches Institut für Bautechnik.

Issued in Berlin on 11 November 2024 by Deutsches Institut für Bautechnik

Anja Dewitt
Head of Section

beglaubigt:
Vössing

Annex 1 – Specifications of intended use

A.1.1 Use of the E-JET X screws only for:

- static and quasi-static loads

A.1.2 Connection material

The screws are used for connections in load bearing timber structures between wood-based members or between timber members and steel members:

- Solid timber (softwood) in accordance with EN 14081-1¹,
- Glued laminated timber in accordance with EN 14080²,
- Laminated veneer lumber LVL of softwood in accordance with EN 14374³, arrangement of the screws only perpendicular to the plane of the veneers,
- Glued solid timber (softwood) in accordance with EN 14080,
- Cross-laminated timber (softwood) in accordance with European Technical Assessments.

The screws are used for connecting the following wood-based panels to the timber members mentioned above:

- Plywood in accordance with EN 636⁴ and EN 13986⁵,
- Oriented strand boards (OSB) in accordance with EN 300⁶ and EN 13986,
- Particleboard in accordance with EN 312⁷ and EN 13986,
- Fibreboards in accordance with EN 622-2⁸, EN 622-3⁹ and EN 13986,
- Cement-bonded particle boards in accordance with EN 634-2¹⁰ and EN 13986,
- Solid-wood panels (SWP) in accordance with EN 13353¹¹ and EN 13986.

Wood-based panels are only arranged on the side of the screw head.

E-JET X screws can be used for the fixing of thermal insulation material on top of rafters or on wood-based members in vertical façades.

E-JET X fully threaded screws made of carbon steel are used for compression and tension reinforcing of timber structures perpendicular to the grain.

1	EN 14081-1:2005+A1:2011	Timber structures - Strength graded structural timber with rectangular cross section - Part 1: General requirements
2	EN 14080:2013	Timber structures - Glued laminated timber and glued solid timber - Requirements
3	EN 14374:2004	Timber structures - Structural laminated veneer lumber - Requirements
4	EN 636:2012+A1:2015	Plywood - Specifications
5	EN 13986:2004+A1:2015	Wood-based panels for use in construction - Characteristics, evaluation of conformity and marking
6	EN 300:2006	Oriented strand boards (OSB) - Definition, classification and specifications
7	EN 312:2010	Particleboards - Specifications
8	EN 622-2:2004/AC:2005	Fibreboards - Specifications - Part 2: Requirements for hardboards
9	EN 622-3:2004	Fibreboards - Specifications - Part 3: Requirements for medium boards
10	EN 634-2:2007	Cement-bonded particleboards - Specifications - Part 2: Requirements for OPC bonded particleboards for use in dry, humid and external conditions
11	EN 13353:2022	Solid wood panels (SWP) - Requirements

E-JET X Screws	Annex 1
Specifications of intended use	

A.1.3 Use Conditions (environmental conditions)

The corrosion protection of the E-JET X screws is specified in Annex A.2.6.

A.1.4 Installation provisions

EN 1995-1-1¹² applies for the installation of E-JET X screws.

A minimum of two screws shall be used for connections in load bearing timber structures.

The screws are driven into the wood-based member made of softwood without pre-drilling. The screw holes in steel members are pre-drilled with an adequate diameter greater than the outer thread diameter.

E-JET X fully threaded screws with an outer thread diameter of 13 mm and 14 mm and a length greater or equal than 800 mm are only driven in a guiding hole with a diameter of 7 mm and a minimum length of 80 mm.

If screws with an outer thread diameter $d \geq 8$ mm are driven into the wood-based member without pre-drilling, the structural solid timber, glued laminated timber, glued solid timber, laminated veneer lumber and cross laminated timber are from spruce, pine or fir.

In the case of fastening counter battens on thermal insulation material on top of rafters the screws are driven in the rafter through the counter battens and the thermal insulation material without pre-drilling in one sequence.

Countersunk head screws can be used with washers in accordance with Annex 5. After inserting the screw, the washers touch the surface of the wood-based member completely.

By fastening screws in wood-based members the head of the screws is flush with the surface of the wood-based member. For cylinder head screws the head part remains unconsidered.

¹² EN 1995-1-1: 2004+AC:2006+A1:2008+A2:2014 Eurocode 5: Design of timber structures - Part 1-1: General - Common rules and rules for buildings

E-JET X Screws	Annex 1
Specifications of intended use	

Annex 2 – Characteristic values of the load-carrying capacities

Table A.2.1 Characteristic load-carrying capacities of E-JET X screws

Outer thread diameter [mm]	6.0	8.0	10.0	12.0	13.0	14.0
Characteristic yield moment $M_{y,k}$ [Nm]	10.0	20.0	30.0	42.0	60.0	68.0
Characteristic tensile strength $f_{tens,k}$ [kN]	12.0	21.0	27.0	36.0	55.0	55.0
Characteristic torsional strength $f_{tor,k}$ [Nm]	10.0	24.0	39.0	58.0	95.0	102.0

A.2.1 General

All E-JET X screws achieve a bending angle α of at least $45/d^{0.7} + 20$, where d is the outer thread diameter of the screws.

The minimum penetration length of the threaded part of the screw in the wood-based members l_{ef} is:

$$l_{ef} = \min \begin{cases} \frac{4 \cdot d}{\sin \alpha} \\ 20 \cdot d \end{cases} \quad (2.1)$$

Where:

l_{ef} penetration length of the threaded part of the screw in the wood-based member [mm],

α angle between screw axis and grain direction [°],

d outer thread diameter of the screw [mm].

The inner thread diameter d_1 of the screws is greater than the maximal width of the gaps in the layer of cross-laminated timber.

A.2.2 Laterally loaded screws

The outer thread diameter d shall be used as effective diameter of the screw in accordance with EN 1995-1-1.

The embedding strength for the screws in wood-based members or in wood-based panels shall be taken from EN 1995-1-1.

A.2.3 Axially loaded screws

A.2.3.1 Slip modulus for mainly axially loaded screws

The axial slip modulus K_{ser} of the threaded part of a screw for the serviceability limit state is independent of angle α to the grain as:

$$K_{ser} = 780 \cdot d^{0.2} \cdot l_{ef}^{0.4} \quad [\text{N/mm}] \quad (2.2)$$

Where:

d outer thread diameter of the screw [mm]

l_{ef} penetration length of the threaded part of the screw in the wood-based member [mm].

E-JET X Screws	Annex 2
Characteristic values of the load-carrying capacities	

A.2.3.2 Axial withdrawal capacity – Characteristic withdrawal parameter

The characteristic withdrawal parameter at an angle $\alpha = 90^\circ$ to the grain based on a associated density of the wood-based member ρ_a of 350 kg/m^3 is:

$f_{ax,k} = 11 \text{ N/mm}^2$ for screws with $6.0 \text{ mm} \leq d \leq 8 \text{ mm}$ and

$f_{ax,k} = 10 \text{ N/mm}^2$ for screws with $d \geq 10 \text{ mm}$.

For LVL a maximum characteristic density of 500 kg/m^3 shall be used in equation (8.40a) of EN 1995-1-1.

A.2.3.3 Head pull-through capacity – Characteristic head pull-through parameter

The characteristic value of the head pull-through parameter for E-JET X screws for a characteristic density ρ_a of 350 kg/m^3 of the timber and for wood-based panels like:

- Plywood in accordance with EN 636 and EN 13986
- Oriented Strand Board, OSB in accordance with EN 300 and EN 13986
- Particleboard in accordance with EN 312 and EN 13986
- Fibreboards in accordance with EN 622-2, EN 622-3 and EN 13986
- Cement-bonded particle boards in accordance with EN 634-2 and EN 13986,
- Solid-wood panels in accordance with EN 13353 and EN 13986

with a thickness of more than 20 mm is:

$f_{head,k} = 9.4 \text{ N/mm}^2$ for screws with countersunk or wafer head.

For wood-based panels a maximum characteristic density of 380 kg/m^3 and for LVL a maximum characteristic density of 500 kg/m^3 shall be used in equation (8.40b) of EN 1995-1-1.

The head diameter shall be equal to or greater than $1.8 \cdot d_s$, where d_s is the smooth shank or the inner thread diameter. Otherwise the characteristic head pull-through capacity in equation (8.40b) of EN 1995-1-1 is for all wood-based materials: $F_{ax,\alpha,RK} = 0$.

For wood-based panels with a thickness $12 \text{ mm} \leq t \leq 20 \text{ mm}$ the characteristic value of the head pull-through parameter for the screws is:

$f_{head,k} = 8 \text{ N/mm}^2$

For wood-based panels with a thickness of less than 12 mm the characteristic head pull-through capacity for screws shall be based on a characteristic value of the head pull-through parameter of 8 N/mm^2 , and limited to 400 N complying with the minimum thickness of the wood-based panels of $1.2 \cdot d$, with d as outer thread diameter and the values in Table A.2.2.

Table A.2.2 Minimum thickness of wood-based panels

Wood-based panel	Minimum thickness [mm]
Plywood	6
Fibreboards (hardboards and medium boards)	6
Oriented strand boards (OSB)	8
Particleboards	8
Cement-bonded particle boards	8
Solid wood panels (SWP)	12

E-JET X Screws	Annex 2
Characteristic values of the load-carrying capacities	

For E-JET X screws with countersunk or wafer head the withdrawal capacity of the thread in the wood-based member with the screw head may be taken into account instead of the head pull-through capacity:

$$F_{ax,\alpha,Rk} = \max \left\{ \begin{array}{l} f_{head,k} \cdot d_h^2 \cdot \left(\frac{\rho_k}{350} \right)^{0,8} \\ \frac{f_{ax,k} \cdot d \cdot l_{ef,k}}{1,2 \cdot \cos^2 \alpha + \sin^2 \alpha} \cdot \left(\frac{\rho_k}{350} \right)^{0,8} \end{array} \right. \quad (2.3)$$

For E-JET X screws with cylinder head the withdrawal capacity of the thread in the wood-based member with the screw head may be taken into account:

$$F_{ax,\alpha,Rk} = \frac{f_{ax,k} \cdot d \cdot l_{ef,k}}{1,2 \cdot \cos^2 \alpha + \sin^2 \alpha} \cdot \left(\frac{\rho_k}{350} \right)^{0,8} \quad (2.4)$$

Where:

- $f_{head,k}$ characteristic value of the head pull-through capacity of the screw [N/mm²]
- $f_{ax,k}$ characteristic value of the axial withdrawal capacity of the threaded part of the screw, $f_{ax,k}$ does not apply for wood-based panels [N/mm²],
- d_h diameter of the screw head [mm],
- ρ_k characteristic density of the wood-based member with the screw head [kg/m³],
- $l_{ef,k}$ penetration length of the threaded part of the screw in the wood-based member with the screw head [mm],
 $l_{ef,k} \geq 4 \cdot d$
- α angle α between screw axis and grain direction, $30^\circ \leq \alpha \leq 90^\circ$.

Outer diameter of washer $d_2 > 32$ mm shall not be considered.

In steel-to-timber connections the head pull-through capacity is not governing.

A.2.3.4 Compressive capacity of E-JET X fully threaded screws - Characteristic yield strength

The design axial capacity $F_{ax,Rd}$ of E-JET X fully threaded screws made of carbon steel embedded in solid timber, glued solid timber or glued laminated timber made from softwood with an angle between screw axis and grain direction of $30^\circ \leq \alpha \leq 90^\circ$ is the minimum of the axial resistance against pushing-in and the buckling resistance of the screw.

$$F_{ax,Rd} = \min \left\{ f_{ax,d} \cdot d \cdot l_{ef}; \kappa_c \cdot N_{pl,d} \right\} \quad (2.5)$$

- $f_{ax,d}$ design value of the axial withdrawal capacity of the threaded part of the screw [N/mm²]
- d outer thread diameter of the screw [mm]
- l_{ef} penetration length of the threaded part of the screw in the timber member [mm]

$$\kappa_c = 1 \quad \text{für } \bar{\lambda}_k \leq 0,2 \quad (2.6)$$

$$\kappa_c = \frac{1}{k + \sqrt{k^2 - \bar{\lambda}_k^2}} \quad \text{für } \bar{\lambda}_k > 0,2 \quad (2.7)$$

$$k = 0,5 \cdot \left[1 + 0,49 \cdot \left(\bar{\lambda}_k - 0,2 \right) + \bar{\lambda}_k^2 \right] \quad (2.8)$$

E-JET X Screws	Annex 2
Characteristic values of the load-carrying capacities	

$$\text{and a relative slenderness ratio } \bar{\lambda}_k = \sqrt{\frac{N_{pl,k}}{N_{ki,k}}} \quad (2.9)$$

Where:

$N_{pl,k}$ characteristic plastic normal force related to the net cross-section

$$\text{of the inner thread diameter: } N_{pl,k} = \pi \cdot \frac{d_1^2}{4} \cdot f_{y,k} \quad (2.10)$$

$f_{y,k}$ characteristic yield strength,

$f_{y,k} = 900 \text{ N/mm}^2$ for E-JET X fully threaded screws made of carbon steel with $d \geq 12 \text{ mm}$ and

$f_{y,k} = 1000 \text{ N/mm}^2$ for E-JET X fully threaded screws made of carbon steel with $6 \text{ mm} \leq d \leq 10 \text{ mm}$

d_1 inner thread diameter of the screw [mm]

$$N_{pl,d} = \frac{N_{pl,k}}{\gamma_{M1}} \quad (2.11)$$

γ_{M1} partial factor in accordance with EN 1993-1-1

Characteristic ideal elastic buckling load:

$$N_{ki,k} = \sqrt{c_h \cdot E_s \cdot I_s} \quad [\text{N}] \quad (2.12)$$

Elastic foundation of the screw:

$$c_h = (0,19 + 0,012 \cdot d) \cdot \rho_k \cdot \left(\frac{90^\circ + \alpha}{180^\circ} \right) [\text{N/mm}^2] \quad (2.13)$$

ρ_k characteristic density of the wood-based member [kg/m^3],

α angle between screw axis and grain direction, $30^\circ \leq \alpha \leq 90^\circ$

Modulus of elasticity:

$$E_s = 210000 \text{ N/mm}^2$$

Second moment of area:

$$I_s = \frac{\pi \cdot d_1^4}{64} \quad [\text{mm}^4] \quad (2.14)$$

E-JET X Screws	Annex 2
Characteristic values of the load-carrying capacities	

A.2.4 Spacings, end and edge distances of the screws and minimum thickness of the wood-based material

A.2.4.1 Laterally and/or axially loaded screws

Screws in non pre-drilled holes

For E-JET X screws minimum spacing and distances are given in EN 1995-1-1, clause 8.3.1.2 and Table 8.2 as for nails in non-predrilled holes. Here, the outer thread diameter d shall be considered.

Minimum thickness for structural members made of solid timber, glued laminated timber, glued solid timber, laminated veneer lumber and cross laminated timber is $t = 30$ mm for screws with $d \leq 8$ mm, $t = 40$ mm for screws with $d = 10$ mm and $t = 100$ mm for screws with $d \geq 12$ mm, if the spacing parallel to the grain and the end distance is at least $25d$. In all other cases minimum thicknesses for E-JET X screws in non-predrilled softwood timber members are given in EN 1995-1-1, clause 8.3.1.2 as for nails in non-predrilled holes.

For Douglas fir members minimum spacing and distances parallel to the grain shall be increased by 50 %.

Minimum distances from loaded or unloaded ends shall be at least $15 \cdot d$ for screws with outer thread diameter $d \geq 8$ mm and timber thickness $t < 5 \cdot d$.

Minimum distances from the unloaded edge perpendicular to the grain may be reduced to $3 \cdot d$ also for timber thickness $t < 5 \cdot d$, if the spacing parallel to the grain and the end distance is at least $25 \cdot d$.

A.2.4.2 Only axially loaded screws

For E-JET X screws the minimum spacings, end and edge distances as well as the minimum member thicknesses are given in EN 1995-1-1, clause 8.3.1.2 and Table 8.2 as for nails in non-predrilled holes and clause 8.7.2, Table 8.6.

A.2.5 Insertion moment

The ratio between the characteristic torsional strength $f_{tor,k}$ and the mean value of insertion moment $R_{tor,mean}$ fulfills the requirement for all screws.

A.2.6 Durability against corrosion

Screws and washers made of carbon steel may have the coatings in accordance with Table A.2.3

Table A.2.3 Coatings of the E-JET X screws

Coating		Minimum thickness of the coating [μm]
Electrogalvanized	Yellow chromated	3
	Brown chromated	
	Black chromated	
	Blue passivated	
Nickel-plated		5
Zinc-nickel coating		5
Zinc flake coating		25
VG Coating		25
Nanocoating		25

E-JET X Screws	Annex 2
Characteristic values of the load-carrying capacities	

Annex 3 – Fastening of thermal insulation material on top of rafters (informative)

A.3.1 General

E-JET X screws are used for the fixing of thermal insulation material on top of rafters or on wood-based members in vertical façades. In the following, the meaning of the word rafter includes wood-based members with inclinations between 0° and 90°.

The thickness of the thermal insulation material is up to 300 mm. The thermal insulation material is applicable as insulation on top of rafters or for façades.

The counter battens are from solid timber in accordance with EN 338/EN 14081-1. The minimum thickness t and the minimum width b of the counter battens are given in table A.3.1:

Table A.3.1 Minimum thickness and minimum width of the counter battens

Outer thread diameter d [mm]	Minimum thickness t [mm]	Minimum width b [mm]
6 and 8	30	50
10	40	60
12, 13 and 14	80	100

Instead of counter battens the wood-based panels specified in chapter A.3.2.1 can be used. Only screws with countersunk head are used for fixing wood-based panels on rafters with thermal insulation material as interlayer.

The minimum width of the rafters is 60 mm.

The spacing between screws is not more than 1.75 m.

Friction forces are not considered for the design of the characteristic axial load of the screws.

The anchorage of wind suction forces shall be considered for design. Screws perpendicular to the grain of the rafter may be arranged where required.

A.3.2 Parallel inclined screws and thermal insulation material in compression

A.3.2.1 Mechanical model

The system of rafter, thermal insulation material on top of rafter and counter battens parallel to the rafter may be considered as a beam on elastic foundation. The counter batten represents the beam, and the thermal insulation material on top of the rafter the elastic foundation. The minimum compressive stress of the thermal insulation material at 10 % deformation, measured in accordance with EN 826¹³, shall be $\sigma_{(10\%)} = 0.05 \text{ N/mm}^2$. The counter batten is loaded perpendicular to the axis by point loads F_b transferred by regularly spaced battens. Further point loads F_s are caused by the shear load of the roof due to dead and snow load, which are transferred from the screw heads into the counter battens.

Instead of counter battens the following wood-based panels may be used to cover the thermal insulation material if they are suitable for that use:

- Plywood in accordance with EN 636 and EN 13986,
- Oriented strand boards (OSB) in accordance with EN 300 and EN 13986,
- Particleboards in accordance with EN 312 and EN 13986
- Fibreboards in accordance with EN 622-2, EN 622-3 and EN 13986.

The minimum thickness of the wood-based panels shall be 22 mm.

The word counter batten includes the meaning of wood-based panels in the following.

¹³ EN 826:2013 Thermal insulating products for building applications - Determination of compression behaviour

E-JET X Screws	Annex 3
Fastening of thermal insulation material on top of rafters	

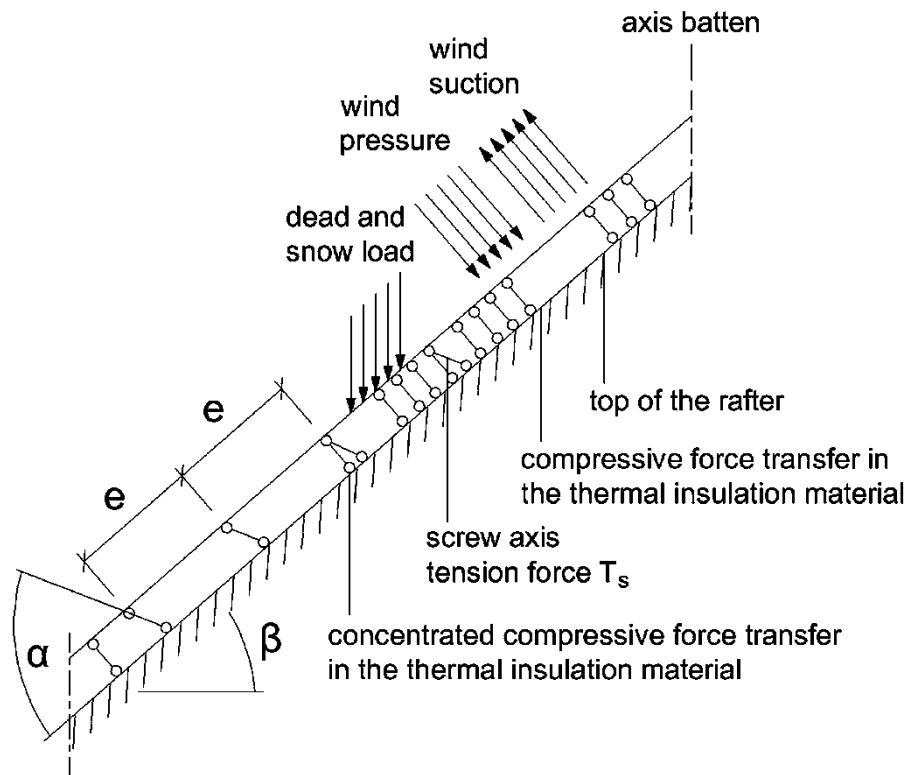
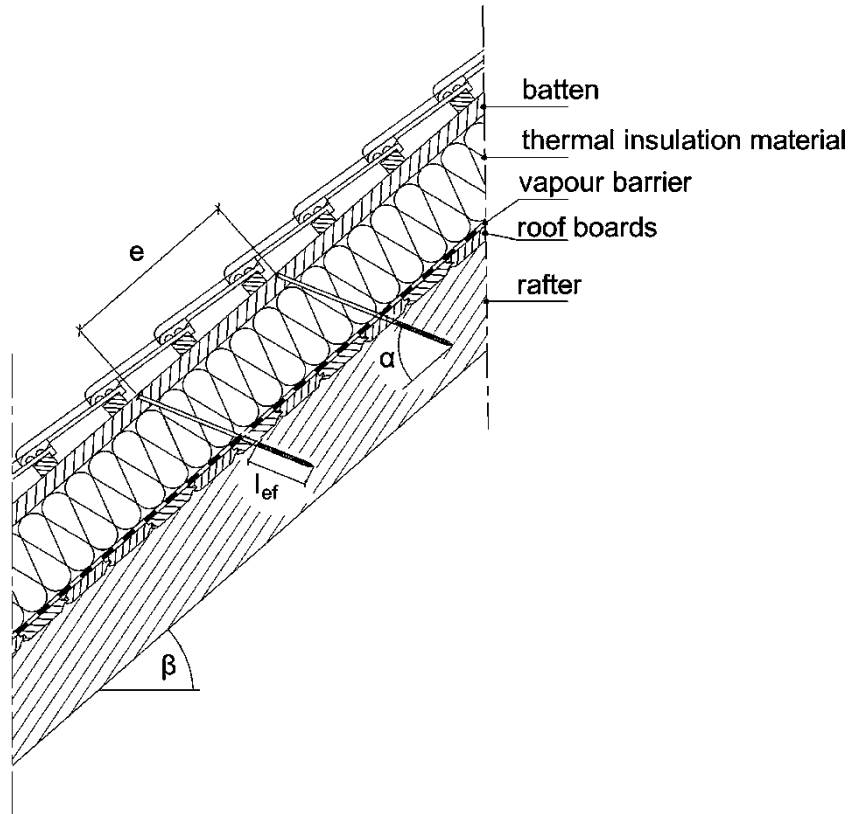

Figure A.3.1 Fastening of the thermal insulation material on top of rafters - structural system

E-JET X Screws	Annex 3
Fastening of thermal insulation material on top of rafters	

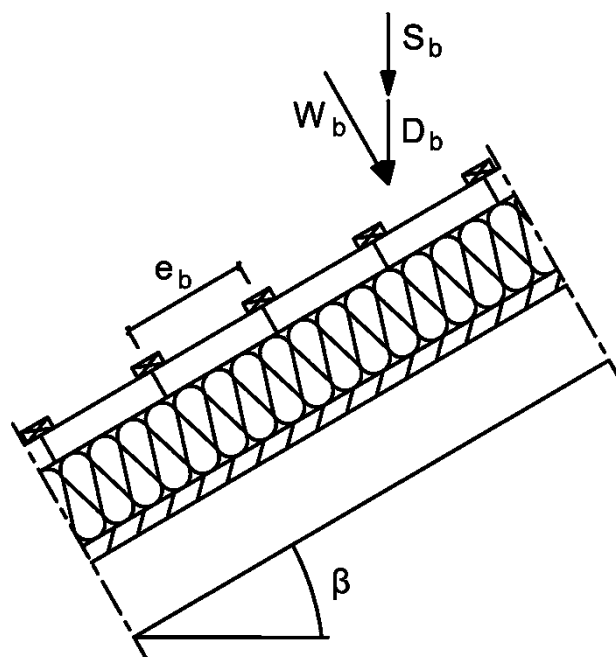

Figure A.3.2 Point loads F_b perpendicular to the counter battens

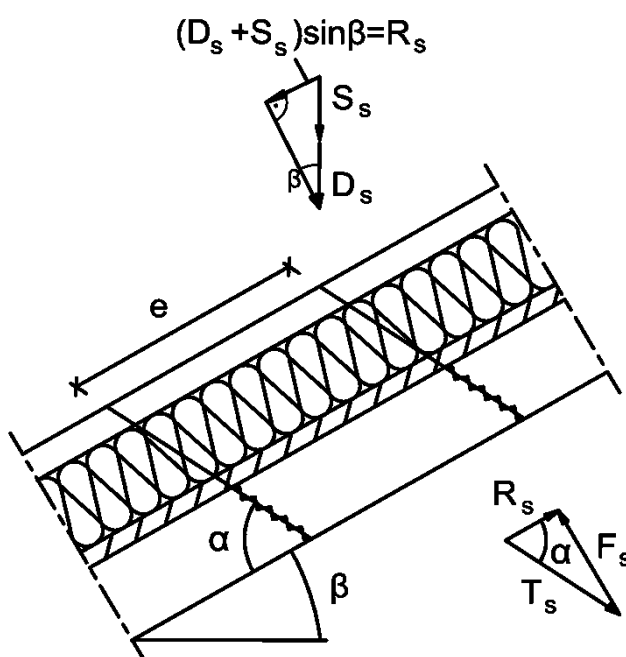

Figure A.3.3 Point loads F_s perpendicular to the counter battens, load application in the area of the screw heads

E-JET X Screws	Annex 3
Fastening of thermal insulation material on top of rafters	

A.3.2.2 Design of the counter battens

It's assumed that the spacing between the counter battens exceeds the characteristic length l_{char} .
The characteristic values of the bending stresses may be calculated as:

$$M_k = \frac{(F_b + F_s) \cdot l_{char}}{4} \quad (3.1)$$

Where:

$$l_{char} = \text{characteristic length } l_{char} = 4 \sqrt{\frac{4 \cdot EI}{w_{ef} \cdot K}} \quad (3.2)$$

EI = bending stiffness of the counter batten

K = modulus of subgrade reaction

w_{ef} = effective width of the thermal insulation material

$F_{b,k}$ = point loads perpendicular to the counter battens

$F_{s,k}$ = point loads perpendicular to the counter battens, load application in the area of the screw heads

The modulus of subgrade reaction K can be calculated from the modulus of elasticity E_{HI} and the thickness t_{HI} of the thermal insulation material if the effective width w_{ef} of the thermal insulation material under compression is known. Due to the load extension in the thermal insulation material the effective width w_{ef} is greater than the width of the counter batten or rafter, respectively. For further calculations, the effective width w_{ef} of the thermal insulation material may be determined in accordance with:

$$w_{ef} = w + t_{HI} / 2 \quad (3.3)$$

Where:

w = minimum from width of the counter batten or rafter, respectively

t_{HI} = thickness of the thermal insulation material

$$K = \frac{E_{HI}}{t_{HI}} \quad (3.4)$$

The following condition shall be satisfied:

$$\frac{\sigma_{m,d}}{f_{m,d}} = \frac{M_d}{W \cdot f_{m,d}} \leq 1 \quad (3.5)$$

For the calculation of the section modulus W the net cross section shall be considered.

The characteristic values of the shear stresses shall be calculated as:

$$V_k = \frac{(F_b + F_s)}{2} \quad (3.6)$$

The following condition need to be satisfied:

$$\frac{\tau_d}{f_{v,d}} = \frac{1.5 \cdot V_d}{A \cdot f_{v,d}} \leq 1 \quad (3.7)$$

For the calculation of the cross-section area the net cross section shall be considered.

A.3.2.3 Design of the thermal insulation material

The characteristic value of the compressive stresses in the thermal insulation material may be calculated as:

$$\sigma_k = \frac{1.5 \cdot F_{b,k} + F_{s,k}}{2 \cdot l_{char} \cdot w} \quad (3.8)$$

The design value of the compressive stress shall not be greater than 110 % of the compressive strength at 10 % deformation calculated in accordance with EN 826.

E-JET X Screws	Annex 3
Fastening of thermal insulation material on top of rafters	

A.3.2.4 Design of the screws

The screws are loaded predominantly axial. The characteristic value of the axial tension force in the screw may be calculated from the characteristic value of the shear loads of the roof $R_{s,k}$:

$$T_{S,k} = \frac{R_{S,k}}{\cos \alpha} \quad (3.9)$$

The load-carrying capacity of axially loaded screws is the minimum design value of the axial withdrawal capacity of the threaded part of the screw, the head pull-through capacity of the screw and the tensile strength of the screw in accordance with Annex 2.

In order to limit the deformation of the screw head for thermal insulation material with thickness over 220 mm or with compressive strength below 0.12 N/mm², respectively, the axial withdrawal capacity of the screws shall be reduced by the factors k_1 and k_2 :

$$F_{ax,\alpha,Rd} = \min \left\{ \frac{f_{ax,d} \cdot d \cdot l_{ef} \cdot k_1 \cdot k_2}{1.2 \cdot \cos^2 \alpha + \sin^2 \alpha} \cdot \left(\frac{\rho_k}{350} \right)^{0.8}; f_{head,d} \cdot d_h^2 \cdot \left(\frac{\rho_k}{350} \right)^{0.8}; \frac{f_{tens,k}}{\gamma_{M2}} \right\} \quad (3.10)$$

Where:

- $f_{ax,d}$ design value of the axial withdrawal parameter of the threaded part of the screw [N/mm²]
- d outer thread diameter of the screw [mm]
- l_{ef} penetration length of the threaded part of the screw in the rafter [mm], $l_{ef} \geq 40$ mm
- ρ_k characteristic density of the wood-based member [kg/m³], for LVL the assumed characteristic density shall not exceed 500 kg/m³
- α angle α between screw axis and grain direction, $30^\circ \leq \alpha \leq 90^\circ$
- $f_{head,d}$ design value of the head pull-through parameter of the screw [N/mm²]
- d_h head diameter of the screw [mm]
- $f_{tens,k}$ characteristic tensile strength capacity of the screw in accordance with Annex 2 [N]
- γ_{M2} partial factor in accordance with EN 1993-1-1¹⁴
- k_1 $\min \{1; 220/t_{HI}\}$
- k_2 $\min \{1; \sigma_{10\%}/0.12\}$
- t_{HI} thickness of the thermal insulation material [mm]
- $\sigma_{10\%}$ compressive stress of the thermal insulation material under 10 % deformation [N/mm²]

If equation (3.10) is fulfilled, the deflection of the counter battens does not need to be considered when designing the load-carrying capacity of the screws.

¹⁴ EN 1993-1-1:2005/AC:2009 Bemessung und Konstruktion von Stahlbauten – Teil 1-1: Allgemeine Bemessung und Regeln für den Hochbau

E-JET X Screws	Annex 3
Fastening of thermal insulation material on top of rafters	

Annex 4 – Compression reinforcement perpendicular to the grain (informative)

A.4.1 General

Only E-JET X fully threaded screws made of carbon steel shall be used for compression reinforcement perpendicular to the grain. The provisions are valid for reinforcing timber members made of solid timber, glued solid timber or glued laminated timber made of softwood.

The compression force shall evenly be distributed to the screws used as compression reinforcement.

The screws are driven into the timber member perpendicular to the contact surface under an angle between the screw axis and the grain direction of 45° to 90°. The screw heads shall be flush with the timber surface.

A.4.2 Design

For the design of reinforced contact areas, the following conditions shall be met independently of the angle between the screw axis and the grain direction.

The design resistance of a reinforced contact area is:

$$R_{90,d} = \min \left\{ \begin{array}{l} k_{c,90} \cdot B \cdot l_{ef,1} \cdot f_{c,90,d} + n \cdot \min \{ R_{ax,d}; \kappa_c \cdot N_{pl,d} \} \\ B \cdot l_{ef,2} \cdot f_{c,90,d} \end{array} \right. \quad (4.1)$$

Where:

$k_{c,90}$ parameter in accordance with EN 1995-1-1, clause 6.1.5

B bearing width [mm]

$l_{ef,1}$ effective contact length in accordance with EN 1995-1-1, clause 6.1.5 [mm]

$f_{c,90,d}$ design compressive strength perpendicular to the grain [N/mm²]

n number of reinforcing screws, $n = n_0 \cdot n_{90}$

n_0 number of reinforcing screws arranged in a row parallel to the grain

n_{90} number of reinforcing screws arranged in a row perpendicular to the grain

$$R_{ax,d} = f_{ax,d} \cdot d \cdot l_{ef} \quad [N] \quad (4.2)$$

$f_{ax,d}$ design value of the axial withdrawal capacity of the threaded part of the screw [N/mm²]

d outer thread diameter of the screw [mm]

κ_c in accordance with Annex A.2.3.4

$N_{pl,d}$ in accordance with Annex A.2.3.4 [N]

$l_{ef,2}$ effective contact length in the plane of the screw tips (see Figure A.4.1) [mm]

$l_{ef,2} = \{ l_{ef} + (n_0 - 1) \cdot a_1 + \min (l_{ef}; a_{1,CG}) \}$ for end supports (see Figure A.4.1 left)

$l_{ef,2} = \{ 2 \cdot l_{ef} + (n_0 - 1) \cdot a_1 \}$ for intermediate supports (see Figure A.4.1 right)

l_{ef} threaded length of the screw in the timber member [mm]

a_1 Spacing a_1 in a plane parallel to grain, see chapter A.2.4.2 [mm]

$a_{1,CG}$ End distance of the centre of gravity of the threaded part in the timber member, see chapter A.2.4.2 [mm]

E-JET X Screws	Annex 4
Compression reinforcement perpendicular to the grain	

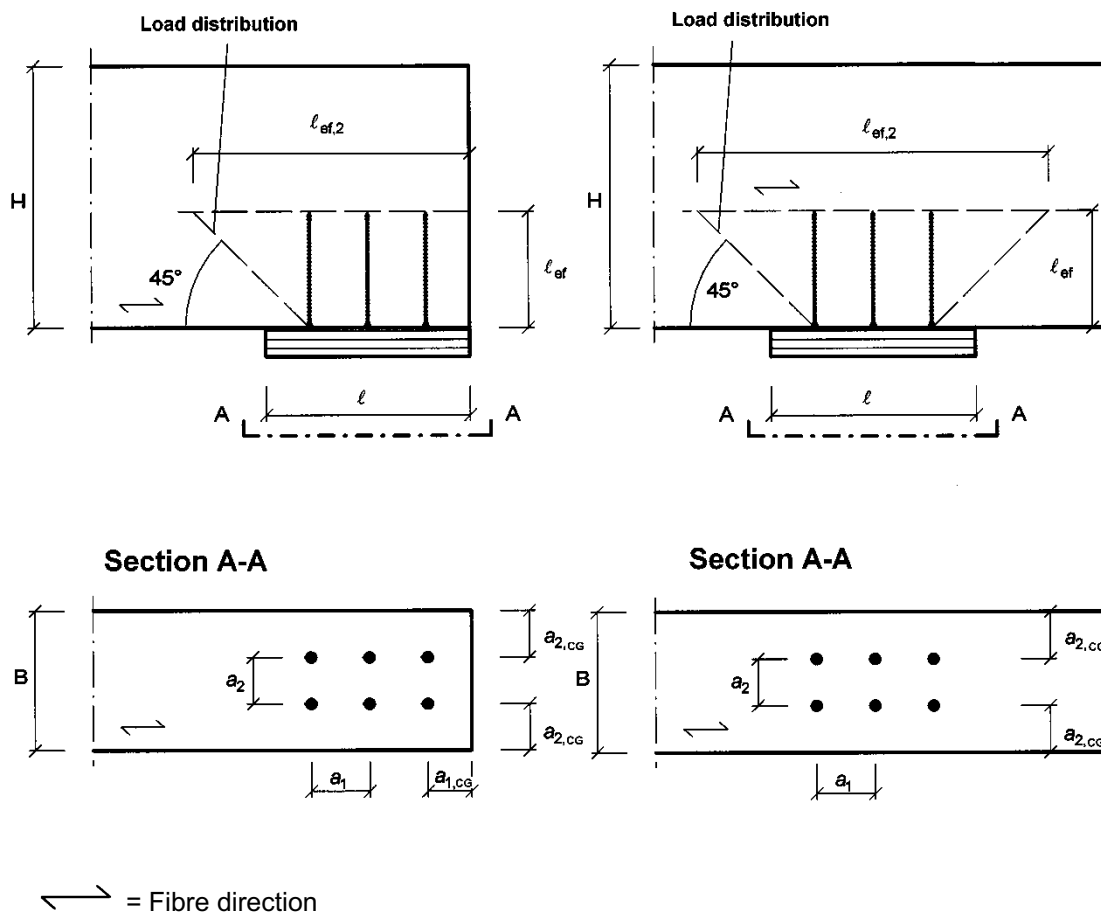
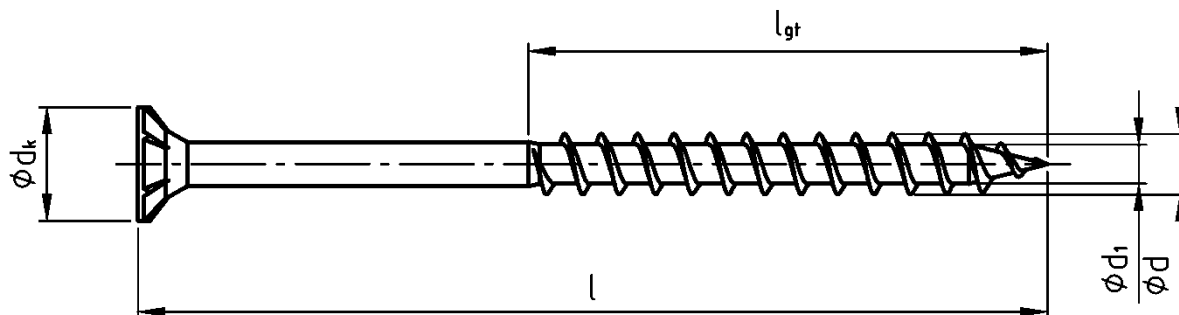

Figure A.4.1: Reinforced end support (left) and reinforced intermediate support (right)

E-JET X Screws	Annex 4
Compression reinforcement perpendicular to the grain	



Partial thread without reamer shank and drilling tip/cutting edge

E-JET® X screws can be manufactured with a thread length l_{gt} and screw heads according to the following annexes as well as with a reamer shank and/or drilling tip/cutting edge.

E-JET X Screws

General description

Annex 5.1

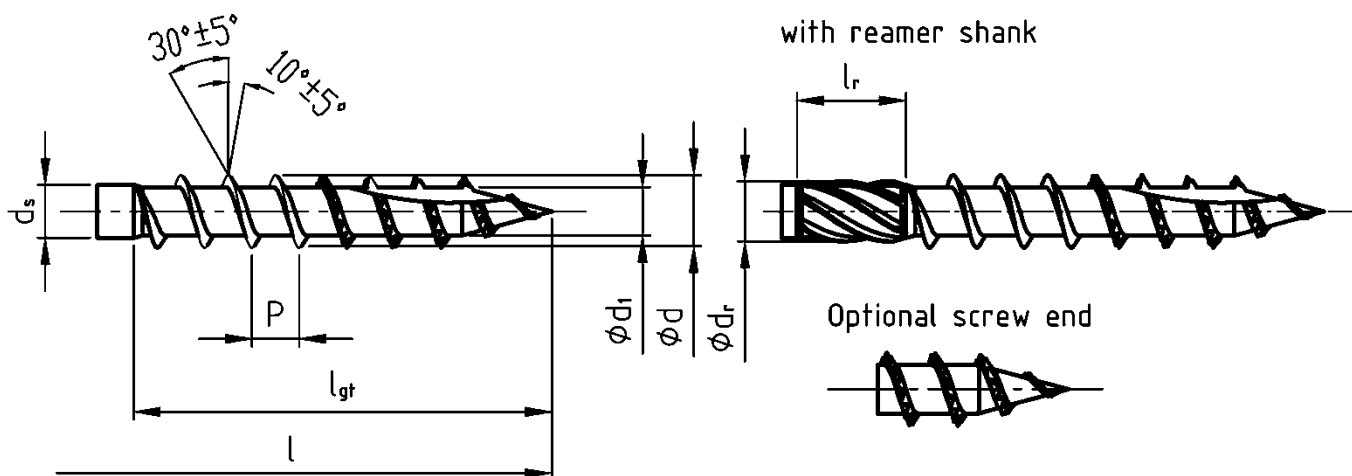

Nominal- ϕ	6		8		10		12	
ϕd	6,00±0,30		8,00±0,40		10,00±0,50		12,00±0,60	
ϕd_1	4,00±0,30		5,20±0,30		6,20±0,30		7,00±0,35	
P ($\pm 10\%$)	l<180: 3,30 l≥180: 4,50		5,20		5,60		6,00	
ϕd_s	4,25±0,30		5,70±0,25		7,00±0,35		8,00±0,40	
l_r	12,00±1,50		12,00±1,50		12,00±1,50		12,00±1,50	
ϕd_t	5,10±0,30		7,00±0,30		8,50±0,30		8,80±0,30	
l	$l_{gt}^{2)}$	Reamer shank ¹⁾	$l_{gt}^{2)}$	Reamer shank ¹⁾	$l_{gt}^{2)}$	Reamer shank ¹⁾	$l_{gt}^{2)}$	Reamer shank ¹⁾
40-80 ($\pm 2,0$)	32-75 ($\pm 2,3$)	0	32-100 ($\pm 2,0$)	0	52-100 ($\pm 2,0$)	0	80-120 ($\pm 2,0$)	0
>80-120 ($\pm 2,7$)		X		X		X		0
>120-180 ($\pm 3,2$)		X		X		X		X
>180-250 ($\pm 3,6$)		X		X		X		X
>250-315 ($\pm 4,1$)		X		X		X		X
>315-400 ($\pm 4,5$)		X		X		X		X
>400-500 ($\pm 4,9$)		X		X		X		X
>500-600 ($\pm 5,5$)		X		X		X		X
¹⁾ 0=optional; X=present ²⁾ Thread length l_{gt} can be manufactured within the specified range								

All dimensions in mm.

E-JET X Screws	Annex 5.2
Screws with d = 6 mm, 8 mm, 10 mm und 12 mm	

Countersunk with ribs under head - flat or raised countersunk head

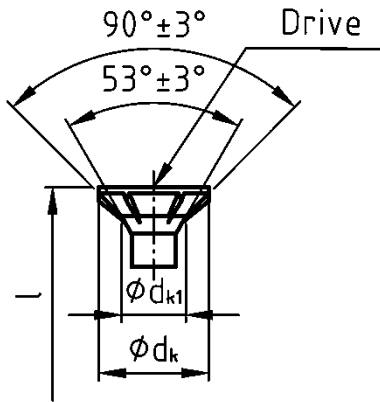

Nominal-ϕ		6	8	10	12
ϕdk		11,50±0,50	14,50±0,50	18,00±0,50	21,00±0,50
ϕdk1		6,25±0,25	8,25±0,25	10,25±0,25	12,25±0,25
Drive	Hexalobular socket Nr.	25 / 30	40	40 / 50	50
	Cross recess	Z3	-	-	-

Hexagon with flange

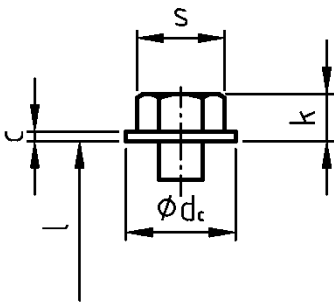

Nominal-ϕ		6	8	10	12
s		8,00-0,22	10,00-0,22	13,00-0,27	16,00-0,27
k		5,00±0,35	6,30±0,35	8,00±0,40	9,00±0,40
ϕdc		12,50±0,50	14,50±0,50	17,50±0,50	21,50±0,50
c		1,20±0,15	1,30±0,15	1,70±0,20	2,20±0,20

Hexagon with flange and hexalobular socket (ISR)

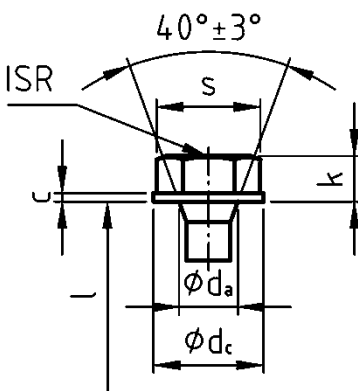

Nominal-ϕ		6	8	10	12
s		-	12,00-0,22	15,00-0,22	17,00-0,27
k		-	6,00±0,20	6,90±0,20	7,95±0,25
ϕdc		-	14,50±0,50	17,50±0,50	23,00±1,00
ϕda		-	7,75±0,25	9,75±0,25	11,75±0,25
c		-	1,10±0,10	1,20±0,10	1,30±0,10
Hexalobular socket Nr		-	40	40	50

All dimensions in mm.

E-JET X Screws	Annex 5.3
Screw head I	

Hexagon with hexalobular socket (ISR)

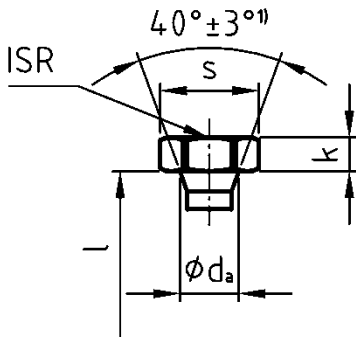

Nominal- ϕ	6	8	10	12
s	9,00-0,30	12,00-0,30	15/17-0,40	17/19-0,40
k	3,00±0,50	4,50±0,50	5,00±0,50	5,50±0,50
ϕ_{da}	7,25±0,25	7,75±0,25	9,75±0,25	11,75±0,25
Hexalobular socket Nr	25	40	40	50
* Nenn- ϕ : 60°±3°				

Wafer head with hexalobular socket (ISR)

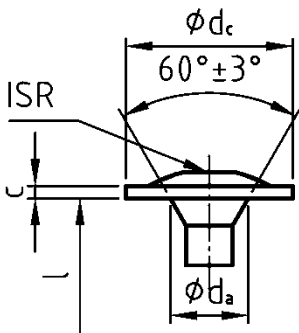

Nominal- ϕ	6	8		10	12	
ϕ_{dc} (±1,00)	15,00	18,00	20,00	22,00	25,00	29,00
ϕ_{da} (±0,50)	7,50	10,00		12,50	14,00	
c	1,30±0,10	1,70±0,10		1,95±0,15	2,25±0,15	
Hexalobular socket Nr	30	40		40 / 50	50	

Pan Head with hexalobular socket (ISR)

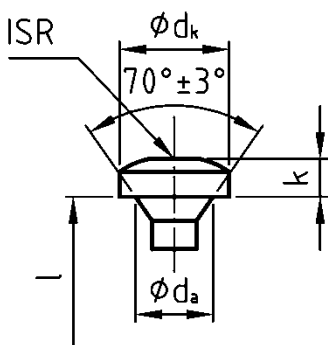

Nominal- ϕ	6	8	10	12
ϕ_{dk}	12,00±0,50	14,50±0,50	18,60±0,60	21,50±0,50
k	4,00±0,50	5,10±0,50	5,50±0,50	6,00±0,50
ϕ_{da}	6,75±0,25	9,75±0,25	12,00±0,25	13,50±0,25
Hexalobular socket Nr	30	40	40 / 50	50

All dimensions in mm.

E-JET X Screws	Annex 5.4
Screw head II	

Cylinder head with hexalobular socket (ISR)

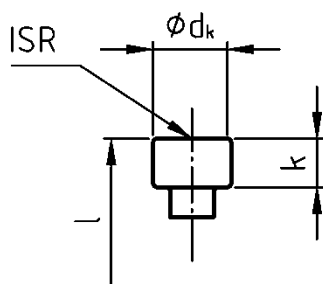

Nominal- ϕ	6	8	10	12
ϕd_k	$7,50 \pm 0,50$	$10,50 \pm 0,50$	$12,50 \pm 0,50$	$14,50 \pm 0,50$
k	$5,00 \pm 0,50$	$6,00 \pm 0,50$	$7,00 \pm 0,50$	$8,00 \pm 0,50$
Hexalobular socket Nr	30	40	50	50

Wide / High cylinder head with hexalobular socket (ISR)

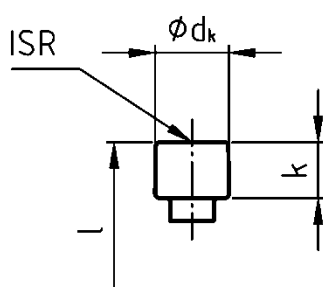

Nominal- ϕ	6	8	10	12
ϕd_k	$8,05 \pm 0,25$	$9,90 \pm 0,30$	$13,40 \pm 0,40$	$14,20 \pm 0,50$
k	$4,70 \pm 0,40$	$7,50 \pm 0,50$	$8,00 \pm 0,50$	$9,60 \pm 0,50$
Hexalobular socket Nr	30	40	50	50

High hexagon with flange and internal thread

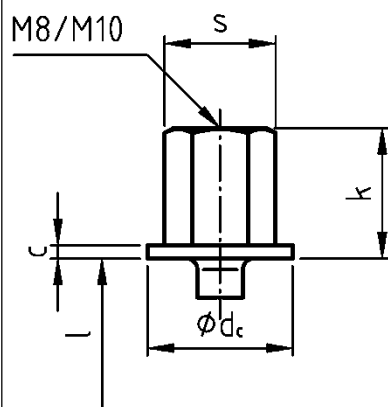

Nominal- ϕ	6	8	10	12
s	-	$13,00 - 0,27$	-	-
k	-	$17,30 \pm 0,30$	-	-
ϕd_c	-	$19,50 \pm 0,30$	-	-
c	-	$1,70 \pm 0,30$	-	-

All dimensions in mm.

E-JET X Screws

Screw head III

Annex 5.5

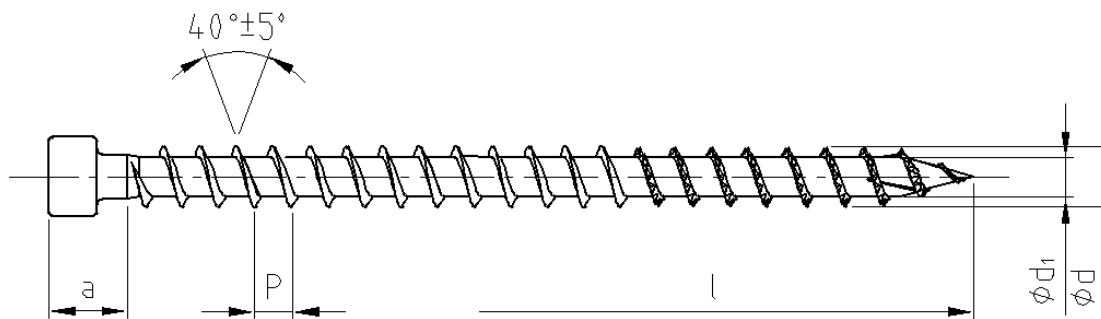

Optional screw ends

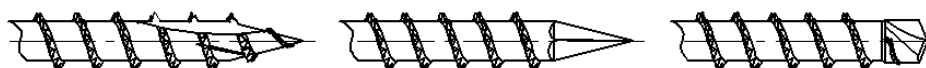

Nenn- ϕ	6	8	10	12	13	14
ϕd	6,00±0,30	8,00±0,40	10,00±0,50	12,00±0,60	13,00±0,65	14,00±0,70
ϕd_1	4,00±0,30	5,20±0,30	6,20±0,30	7,00±0,35	8,00±0,40	8,50±0,40
P	3,80±10%	4,80±10%	5,60±10%	6,00±10%	6,00±10%	6,80±10%
a max.	12,00	19,00	20,00	20,50	21,00	22,00
l	100-120(±2,7)	100-120(±2,7)	100-120(±2,7)	100-120(±2,7)		
	>120-180(±3,2)	>120-180(±3,2)	>120-180(±3,2)	>120-180(±3,2)		
	>180-250(±3,6)	>180-250(±3,6)	>180-250(±3,6)	>180-250(±3,6)	200-250(±3,6)	200-250(±3,6)
	>250-300(±4,1)	>250-315(±4,1)	>250-315(±4,1)	>250-315(±4,1)	>250-315(±4,1)	>250-315(±4,1)
		>315-400(±4,5)	>315-400(±4,5)	>315-400(±4,5)	>315-400(±4,5)	>315-400(±4,5)
		>400-500(±4,9)	>400-500(±4,9)	>400-500(±4,9)	>400-500(±4,9)	>400-500(±4,9)
			>500-600(±5,5)	>500-630(±5,5)	>500-630(±5,5)	>500-630(±5,5)
				>630-800(±6,3)	>630-800(±6,3)	>630-800(±6,3)
				>800-1000(±7,0)	>800-1000(±7,0)	>800-1000(±7,0)
					>1000-1200(±8,3)	>1000-1250(±8,3)
					>1250-1500(±9,3)	

All dimension in mm.

E-JET X Screws

Fully threaded screws with d = 6 mm, 8 mm, 10 mm, 12 mm, 13 mm and 14 mm

Annex 5.6

Countersunk with ribs under head - flat or raised countersunk head

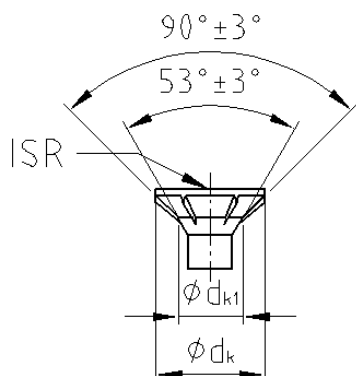

Nom.-φ	6	8	10	12	13	14
φdk	11,50±0,50	14,50±0,50	18,00±0,50	21,00±0,50	21,50±0,50	22,00±0,50
φdk1	6,25±0,25	8,25±0,25	10,25±0,25	12,25±0,25	13,25±0,25	14,25±0,25
ISR-Nr.	25/30	40	40/50	50	50	50

Hexagon with flange

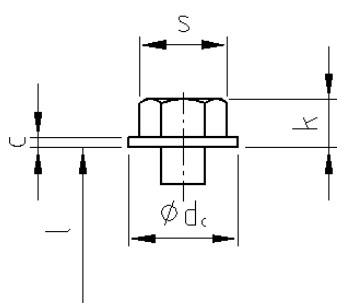

Nom.-φ	6	8	10	12	13	14
s	8,00-0,22	10,00-0,22	13,00-0,27	-	-	-
k	5,00±0,35	6,30±0,35	8,00±0,40	-	-	-
φdc	12,50±0,50	14,50±0,50	17,50±0,50	-	-	-
c	1,20±0,15	1,30±0,15	1,70±0,20	-	-	-

Hexagon with flange and hexalobular socket (ISR)

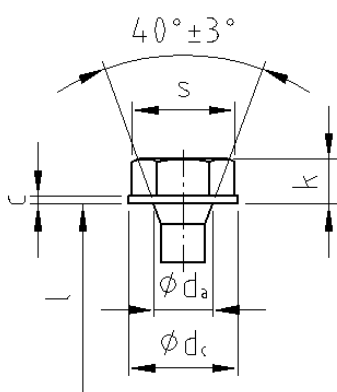

Nom.-φ	6	8	10	12	13	14
s	-	12,00-0,22	15,00-0,22	-	-	-
k	-	6,00±0,20	6,90±0,20	-	-	-
φdc	-	14,50±0,50	17,50±0,50	-	-	-
φda	-	7,75±0,25	9,75±0,25	-	-	-
c	-	1,10±0,10	1,20±0,10	-	-	-
ISR-Nr.	-	40	40	-	-	-

All dimensions in mm.

E-JET X Screws

Fully threaded screws head I

Annex 5.7

Hexagon with hexalobular socket (ISR)

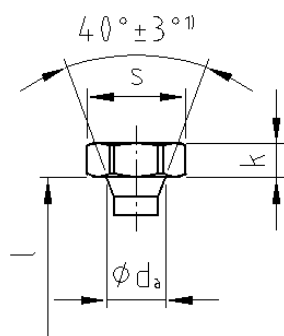

Nom.-φ	6	8	10	12	13	14
s	9,00-0,30	12,00-0,30	15/17-0,40	17/19-0,40	17/19-0,40	17/19-0,40
k	3,00±0,50	4,50±0,50	5,00±0,50	5,50±0,50	6,00±0,50	6,00±0,50
φda	7,25±0,25	7,75±0,25	9,75±0,25	11,75±0,25	11,75±0,25	11,75±0,25
ISR-Nr.	25	40	40	50	50	50

¹⁾ Nenn-φ6: 60°±3°

Wafer head with hexalobular socket (ISR)

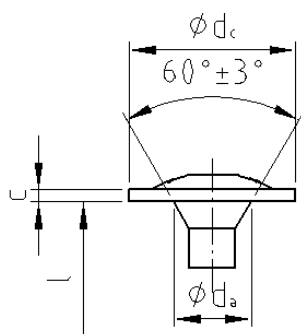

Nom.-φ	6	8	10	12	13	14
φdc (±1,00)	15,00	18 20 22	25,00	29,00	29,00	29,00
φda	7,50±0,50	10,00±0,50	12,50±0,50	14,00±0,50	14,00±0,50	14,00±0,50
c	1,30±0,10	1,70±0,10	1,95±0,15	2,25±0,15	2,25±0,15	2,25±0,15
ISR-Nr.	30	40	40 / 50	50	50	50

Pan Head with hexalobular socket (ISR)

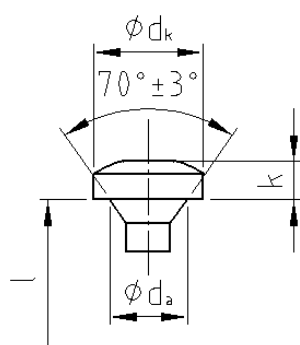

Nom.-φ	6	8	10	12	13	14
φdk	12,00±0,50	14,50±0,50	18,60±0,60	21,50±0,50	-	-
k	4,00±0,50	5,10±0,50	5,50±0,50	6,00±0,50	-	-
φda	6,75±0,25	9,75±0,25	12,00±0,25	13,50±0,25	-	-
ISR-Nr.	30	40	40 / 50	50	-	-

All dimensions in mm.

E-JET X Screws

Fully threaded screws head II

Annex 5.8

Cylinder head with hexalobular socket (ISR)

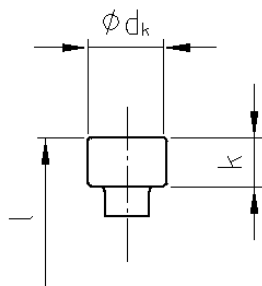

Nom.- ϕ	6	8	10	12	13	14
ϕdk	$7,50 \pm 0,50$	$10,50 \pm 0,50$	$12,50 \pm 0,50$	$14,50 \pm 0,50$	$14,50 \pm 0,50$	$14,50 \pm 0,50$
k	$5,00 \pm 0,50$	$6,00 \pm 0,50$	$7,00 \pm 0,50$	$8,00 \pm 0,50$	$9,00 \pm 0,50$	$10,00 \pm 0,50$
ISR-Nr.	30	40	50	50	50	50

Wide / High cylinder head with hexalobular socket (ISR)

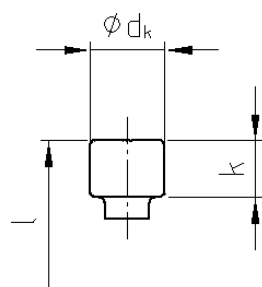

Nom.- ϕ	6	8	10	12	13	14
ϕdk	$8,05 \pm 0,25$	$9,90 \pm 0,30$	$13,40 \pm 0,40$	$14,20 \pm 0,50$	$18,50 \pm 0,50$	$18,50 \pm 0,50$
k	$4,70 \pm 0,40$	$7,50 \pm 0,50$	$8,00 \pm 0,50$	$9,60 \pm 0,50$	$10,50 \pm 0,50$	$10,50 \pm 0,50$
ISR-Nr.	30	40	50	50	50	50

All dimensions in mm.

E-JET X Screws

Fully threaded screws head III

Annex 5.9

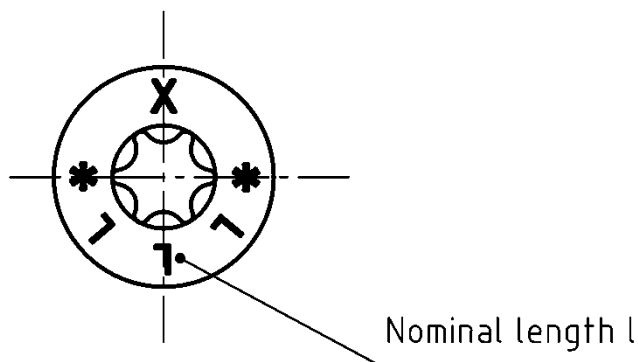

Marking of nominal- \varnothing 6-12 of head types:
Countersunk, hexagon with hexalobular socket, pan head and wafer head.
The named head types can also be manufactured without marking.

E-JET X Screws	Annex 5.10
Head marking	

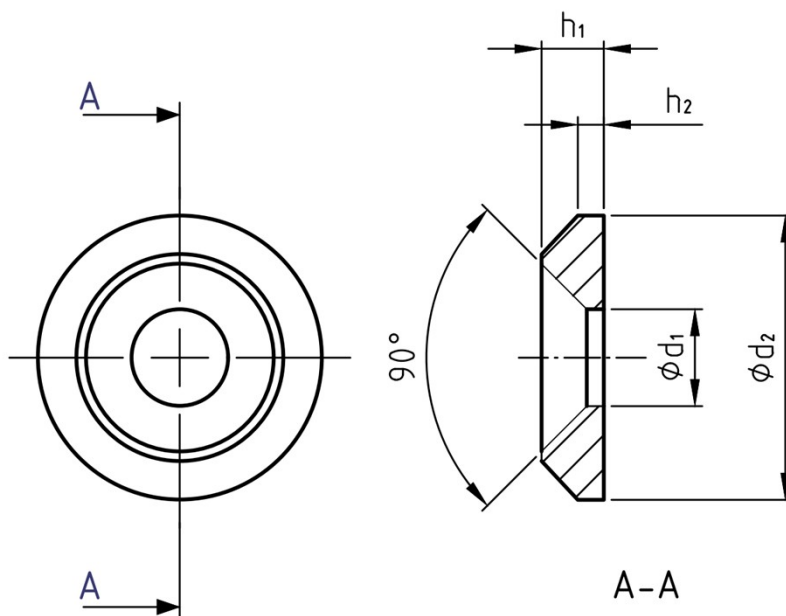

Nominal- ϕ	ϕd_1	ϕd_2	h_1	h_2
6	$7,5 \pm 0,4$	$19,5 \pm 0,4$	$4,5 \pm 0,3$	$1,7 \pm 0,3$
8	$8,5 \pm 0,4$	$25,0 \pm 0,4$	$5,5 \pm 0,3$	$2,3 \pm 0,3$
10	$11,0 \pm 0,4$	$30,0 \pm 0,4$	$6,5 \pm 0,3$	$3,2 \pm 0,3$
12	$14,0 \pm 0,4$	$37,4 \pm 0,4$	$8,5 \pm 0,3$	$2,5 \pm 0,3$

All dimensions in mm.

E-JET X Screws

Washer

Annex 5.11